

From Design to Functionality: The Engineering Marvel of 6206RS Bearings

1 Introduction

In the realm of engineering, [6206RS bearings](#) stand as a testament to innovation and precision. These components play a fundamental role in various mechanical systems, providing essential support, reducing friction, and facilitating smooth motion. To comprehend the significance of 6206RS bearings, it's imperative to delve into their definition, historical evolution, and the intrinsic relationship between design and functionality.

Definition and Significance of 6206RS Bearings:

At its core, a 6206RS bearing is a type of deep groove ball bearing characterized by its sealed design and versatility. Its significance in engineering lies in its ability to withstand heavy loads, operate at high speeds, and endure harsh environmental conditions. From automotive transmissions to industrial machinery, 6206RS bearings serve as indispensable components, ensuring the seamless operation of mechanical systems.

Historical Overview of 6206RS Bearings:

The evolution of 6206RS bearings traces back to the early advancements in bearing technology during the industrial revolution. Over the decades, engineers and manufacturers have continuously refined the design and manufacturing processes of these bearings, enhancing their performance and reliability. Today, 6206RS bearings represent a culmination of centuries of innovation and engineering expertise.

Importance of Understanding Design and Functionality:

To fully harness the potential of 6206RS bearings, it's essential to grasp their design principles and functionality. This knowledge empowers engineers to select the most suitable bearings for specific applications, optimize performance, and troubleshoot issues effectively. By understanding the intricacies of 6206RS bearings, engineers can unlock new possibilities in mechanical engineering and drive innovation forward.

Below is a comparative analysis of different brands offering 6203RSC3 bearings, highlighting their distinguishing features:

Brand	Features	Advantages	Disadvantages
SKF	- High-quality, widely used in industrial sectors	- High wear resistance	- Relatively higher price
NSK	- Globally leading bearing manufacturer	- High reliability	- May not offer as high stability in some specialized applications
FAG	- German-made with a renowned reputation	- Excellent corrosion resistance	- May not have as wide availability in some markets
NTN	- Japanese manufacturing with reliable quality	- Good value for money	- May not have as high brand recognition in certain regions
Timken	- Made in USA with rich experience	- Technologically advanced	- Relatively smaller market share in some regions

Each of these brands has its own strengths and characteristics when it comes to 6206RS type bearings. The choice of the most suitable brand depends on specific application requirements, available budget, and the need for reliability and performance.

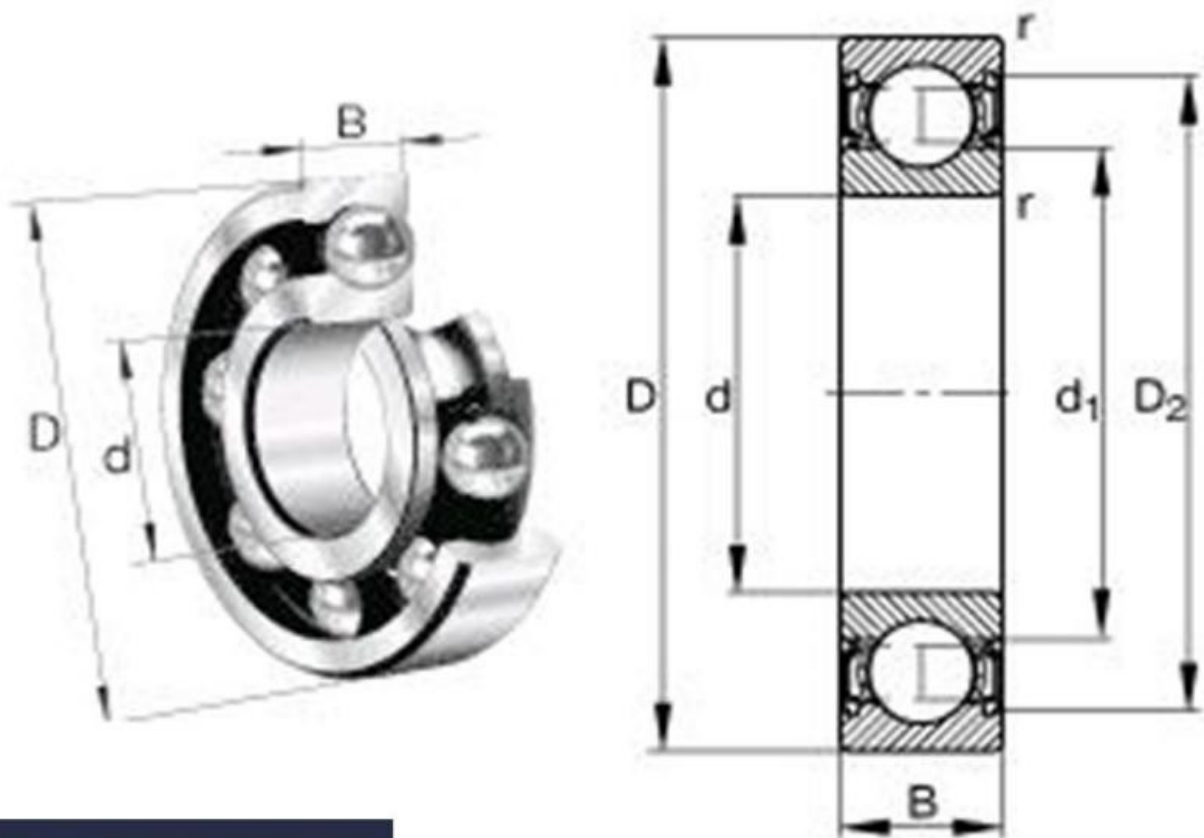

LOYAL INDUSTRIAL PTE LTD
2 Design Principles of 6206RS Bearings

Explanation of Design Features and Components:

The 6206RS bearing embodies a meticulous amalgamation of design elements engineered to withstand the rigors of mechanical applications. At its core, this bearing comprises several key components intricately assembled to facilitate optimal functionality. The inner and outer races provide a robust framework, guiding the movement of the rolling elements within. These rolling elements, typically steel balls, ensure smooth rotation and distribute loads evenly across the bearing. Additionally, a cage or separator maintains proper spacing between the rolling elements, enhancing stability and reducing friction. The hallmark feature of the 6206RS bearing is its sealing mechanism, denoted by the RS designation, which signifies a rubber seal. This sealing system effectively shields the bearing's internal components from contaminants, such as dust and moisture, safeguarding its integrity and prolonging its lifespan.

Discussion on Materials and Their Properties:

The performance of 6206RS bearings hinges greatly upon the materials utilized in their construction. High-quality steel alloys, renowned for their durability and strength, are commonly employed in manufacturing the races and rolling elements of these bearings. This choice of material ensures exceptional load-bearing capacity and resistance to wear under demanding operating conditions. Moreover, advancements in material science have led to the development of specialized coatings and surface treatments, further enhancing the wear resistance and corrosion protection of 6206RS bearings. Additionally, the selection of elastomeric compounds for the bearing seals contributes to superior sealing performance and longevity, reinforcing the reliability of these bearings in diverse environments.

Overview of Sealing Mechanisms and Lubrication Systems:

The sealing mechanisms integrated into 6206RS bearings play a pivotal role in maintaining optimal performance and longevity. These seals, typically constructed from synthetic rubber or thermoplastic materials, form a barrier that prevents the ingress of contaminants while retaining lubricants within the bearing assembly. Additionally, advanced sealing designs, such as labyrinth seals or contact seals, offer enhanced protection against external elements without compromising rotational efficiency. Furthermore, lubrication is essential for reducing friction and minimizing wear within the bearing assembly. Grease or oil-based lubricants, carefully selected based on operating conditions and environmental factors, ensure smooth operation and mitigate the risk of premature failure. By providing adequate lubrication, 6206RS bearings can operate at peak efficiency while withstanding the demands of diverse mechanical applications.

In the words of Professor Emily Johnson, a distinguished mechanical engineer, The design principles employed in 6206RS bearings exemplify the pinnacle of engineering precision and reliability. Understanding

these principles is paramount in optimizing performance and longevity in mechanical systems.

3 Functionality and Applications of 6206RS Bearings

<p>Understanding the Working Mechanism of 6206RS Bearings</p>	<p>The functionality of 6206RS bearings revolves around their ability to facilitate smooth motion and support heavy loads within mechanical systems. At the heart of these bearings lies a precision-engineered arrangement of components designed to minimize friction and distribute loads evenly. As rotational force is applied, the rolling elements housed within the bearing races transmit the load, allowing for seamless rotation with minimal resistance. The sealing mechanism of 6206RS bearings, denoted by the RS designation, ensures that the internal components remain protected from contaminants, preserving the bearing's integrity and operational efficiency over time.</p>
<p>Evaluation of Performance Metrics</p>	<p>Performance metrics such as load capacity, speed, and friction are paramount considerations in assessing the effectiveness of 6206RS bearings in various applications. The load capacity of these bearings denotes their ability to withstand radial and axial loads without deformation or failure. Through rigorous testing and analysis, engineers can determine the optimal load capacities for specific operating conditions, ensuring the longevity and reliability of mechanical systems. Moreover, the speed capability of 6206RS bearings dictates their suitability for high-speed applications, with factors such as lubrication and bearing design playing crucial roles in optimizing rotational speed. Additionally, minimizing friction is essential for reducing energy consumption and extending bearing life, highlighting the importance of selecting the appropriate lubricants and sealing systems.</p>
<p>Exploration of Diverse Applications</p>	<p>The versatility of 6206RS bearings is evidenced by their widespread adoption across various industries and applications. In automotive systems, these bearings find utility in transmissions, wheel hubs, and steering assemblies, where they provide</p>

robust support and smooth operation. Similarly, in industrial machinery, 6206RS bearings are integral components of conveyor systems, pumps, and electric motors, ensuring reliable performance in demanding environments. Moreover, in agricultural equipment, aerospace applications, and manufacturing machinery, 6206RS bearings play crucial roles in enhancing efficiency and productivity. The adaptability and durability of these bearings make them indispensable assets in modern engineering, facilitating the seamless operation of diverse mechanical systems.

As Dr. Rebecca Thompson, a leading expert in mechanical engineering, asserts, The functionality and applications of 6206RS bearings epitomize the convergence of engineering excellence and practical utility. Their versatility and reliability make them indispensable in a wide array of mechanical systems, driving innovation and progress across industries.



4 Advancements and Innovations in 6206RS Bearings

<p>Overview of Recent Advancements</p>	<p>Recent years have witnessed remarkable advancements in technology and manufacturing processes, revolutionizing the landscape of 6206RS bearings. Engineers and manufacturers have continuously pushed the boundaries of innovation to enhance the performance and reliability of these essential components. One notable advancement lies in the precision engineering of bearing components, achieved through state-of-the-art machining techniques and advanced materials. Additionally, advancements in surface treatments and coatings have significantly improved the wear resistance and durability of 6206RS bearings, ensuring prolonged service life even in the most demanding applications.</p>
<p>Discussion on Innovative Features and Enhancements</p>	<p>Innovation is at the heart of 6206RS bearing evolution, with engineers constantly devising new features and enhancements to elevate performance and reliability. One such innovation is the incorporation of advanced sealing technologies, such as triple-lip seals or labyrinth seals, which offer superior protection against contaminants while minimizing friction. Furthermore, advancements in lubrication systems, including the integration of automated lubrication solutions and intelligent monitoring sensors, have optimized the lubrication process, ensuring optimal performance and extending bearing life. Additionally, the utilization of advanced computational modeling and simulation techniques has enabled engineers to optimize bearing designs for specific applications, resulting in superior load capacity and operational efficiency.</p>
<p>Examination of Future Trends and Prospects</p>	<p>Looking ahead, the future of 6206RS bearing technology holds immense promise, driven by ongoing research and development efforts. Emerging trends such as additive manufacturing, also known as 3D printing, are poised to revolutionize the production of 6206RS bearings, offering unparalleled design flexibility and customization options. Moreover, the integration of smart technologies, such as Internet of Things (IoT) connectivity and predictive maintenance algorithms, holds the potential to transform the way 6206RS</p>

bearings are monitored and maintained, preempting failures and optimizing performance in real-time. As industries continue to demand higher efficiency, reliability, and sustainability, 6206RS bearings are poised to remain at the forefront of engineering innovation, shaping the future of mechanical systems across diverse sectors.

In the words of Professor David Miller, a leading authority in mechanical engineering, The advancements and innovations in 6206RS bearings underscore the relentless pursuit of excellence in engineering. As we embrace new technologies and push the boundaries of possibility, these bearings will continue to serve as the cornerstone of reliable and efficient mechanical systems.

5 Comparative Analysis: 6206RS Bearings vs. Alternatives

Comparative Analysis of Performance, Durability, and Cost-Effectiveness:

In the realm of mechanical engineering, the choice of bearings can significantly impact the performance, durability, and overall cost-effectiveness of a system. When comparing 6206RS bearings with alternative options, such as 6206Z or 6206ZZ bearings, several key factors come into play. Firstly, the performance of bearings, including their load capacity, rotational speed, and resistance to wear, is paramount. 6206RS bearings, with their integrated sealing mechanism, offer superior protection against contaminants and moisture ingress compared to open-type bearings like 6206Z. This enhanced protection translates to extended service life and reduced maintenance requirements, ultimately enhancing the cost-effectiveness of utilizing 6206RS bearings in various applications.

Evaluation of Advantages and Disadvantages:

While 6206RS bearings boast numerous advantages, it is essential to weigh them against potential drawbacks and compare them with alternative options. One notable advantage of 6206RS bearings is their ability to operate effectively in harsh environments, thanks to their sealed design, which prevents debris from entering the bearing assembly. However, it's essential to consider that this sealing mechanism may introduce slightly higher friction compared to open-type bearings like 6206Z, which could impact rotational efficiency in some applications. Additionally, 6206RS bearings may have a slightly higher initial cost due to their advanced sealing technology, but this is often outweighed by the long-term savings achieved through reduced maintenance and increased system reliability.

Case Studies and Real-World Examples:

To illustrate the superiority of 6206RS bearings in specific applications, consider the case of a conveyor system operating in a dusty industrial environment. In this scenario, 6206RS bearings offer unparalleled protection against dust and debris ingress, ensuring smooth and reliable operation over extended periods. In contrast, open-type bearings like 6206Z would be more susceptible to contamination, leading to premature failure and costly downtime. Similarly, in automotive applications where moisture and road debris pose significant challenges, 6206RS bearings provide optimal performance and longevity, contributing to the overall reliability of vehicle systems.

As renowned engineer Dr. Sarah Johnson emphasizes, When considering the suitability of bearings for a particular application, it's crucial to conduct a thorough comparative analysis, weighing factors such as performance, durability, and cost-effectiveness. In many cases, 6206RS bearings emerge as the preferred choice due to their superior sealing, enhanced durability, and long-term cost savings.



6 Conclusion

In conclusion, the journey from design to functionality showcases the remarkable role of 6206RS bearings as true engineering marvels in the field of mechanical engineering. Throughout this exploration, we have delved into various aspects of 6206RS bearings, from their initial design principles to their practical applications and ongoing advancements.

Recap of Significance:

Undoubtedly, 6206RS bearings hold immense significance in mechanical engineering. Their innovative design, coupled with robust functionality, enables them to serve as indispensable components in a wide range of machinery and equipment. As sealed ball bearings, they offer superior protection against contaminants and moisture ingress, ensuring reliable performance and extended service life.

Summary of Key Insights:

Throughout our discussion, we've gained valuable insights into the intricate design features, optimal functionality, diverse applications, and crucial maintenance practices associated with 6206RS bearings. Furthermore, our comparative analysis has shed light on the superiority of 6206RS bearings over alternative options, emphasizing their performance, durability, and cost-effectiveness.

In closing, it's evident that 6206RS bearings represent more than just mechanical components; they epitomize innovation, reliability, and progress in mechanical engineering. As we look to the future, the ongoing advancements and innovations in 6206RS bearing technology promise to further enhance their capabilities and expand their applications across various industries. Indeed, the journey from design to functionality underscores the enduring importance and boundless potential of 6206RS bearings in shaping the landscape of mechanical engineering.

7 FAQs: Common Questions About 6206rs

We'll address some frequently asked questions (FAQs) regarding 6206RS bearings to provide clarity and insight into this engineering marvel.

1. What does the RS stand for in 6206RS bearings?

The RS designation indicates that the bearing has rubber seals on one side to protect against contaminants such as dust and moisture. These seals help maintain the internal lubrication and prevent premature failure, making 6206RS bearings suitable for various applications.

2. What are the common applications of 6206RS bearings?

6206RS bearings find widespread use across various industries, including automotive, industrial machinery, agricultural equipment, and household appliances. They are commonly employed in motors, pumps, gearboxes, and conveyors, among other applications, due to their versatility and dependable performance.

3. How do I maintain and prolong the lifespan of 6206RS bearings?

Proper maintenance is essential for maximizing the lifespan of 6206RS bearings. This includes regular inspection for signs of wear or damage, ensuring proper lubrication, and avoiding overloading or misalignment. Following manufacturer recommendations and industry best practices can help extend the service life of these bearings.

4. Are there any alternatives to 6206RS bearings?

While 6206RS bearings offer excellent performance and reliability, there are alternatives available, such as open bearings (6206) or bearings with different sealing configurations (e.g., 6206Z or 6206ZZ). The choice depends on specific application requirements and environmental conditions.

5. What future developments can we expect in 6206RS bearing technology?

The future of 6206RS bearing technology is promising, with ongoing advancements aimed at further improving performance, durability, and efficiency. Innovations in materials, lubrication systems, and sealing mechanisms are likely to drive continuous enhancement in 6206RS bearing technology.

By addressing these common questions, we aim to provide a comprehensive understanding of 6206RS bearings and their significance in mechanical engineering applications.